

Product Specification

Customer: _____
Model Name: TYB0701TE50RT-118B
Date: _____
Version: _____

Preliminary Specification

Final Specification

For Customer's Acceptance

Approved by	Comment

Approved by	Reviewed by	Prepared by

Table of Contents

1. Record of Revision.....	3
2 General Specifications.....	4
3 Input/Output Terminals.....	5
4 Absolute Maximum Ratings.....	8
5 Electrical Characteristics.....	9
6 Optical Characteristics.....	14
7 Environmental / Reliability Tests.....	17
8 Mechanical Drawing.....	18
9 Packing.....	19
10 Precautions For Use of LCD modules.....	19



2 General Specifications

	Feature	Spec
Characteristics	Size	7 inch
	Resolution	800(horizontal)*480(Vertical)
	Interface	24-bit RGB
	Connect type	Connector
	Color Depth	16.7M
	Technology type	a-Si
	Display Spec. Pixel pitch (mm)	0.0642 x 0.1790
	Pixel Configuration	R.G.B. Vertical Stripe
	Display Mode	Normally White
	Driver IC	-
	Surface Treatment	HC
	Viewing Direction	12 O'clock
Gray Viewing Direction	6 O'clock	
Mechanical	LCM (W x H x D) (mm)	164.9*100.0*3.5
	Active Area(mm)	154.08 x 85.92
	With /Without TSP	Without TSP
	Weight (g)	TBD
	LED Numbers	18 LEDs

Note 1: Viewing direction is follow the data which measured by optics equipment.

Note 2: Requirements on Environmental Protection: RoHS

Note 3: LCM weight tolerance: +/- 5%

3 Input/Output Terminals

No.	Symbol	Description
1, 2	VLED+	Power for LED backlight (Anode)
3, 4	VLED-	Power for LED backlight (Cathode)
5	GND	Power Ground
6	VCOM	Common voltage
7	DVDD	Power for Digital Circuit
8	MODE	DE/SYNC mode select Note1
9	DE	Data Enable
10	VS	Vertical sync signal
11	HS	Horizontal sync Signal
12	B7	Blue data(MSB)
13	B6	Blue data
14	B5	Blue data
15	B4	Blue data
16	B3	Blue data
17	B2	Blue data
18	B1	Blue data Note2
19	B0	Blue data(LSB) Note2
20	G7	Green data(MSB)
21	G6	Green data
22	G5	Green data
23	G4	Green data
24	G3	Green data
25	G2	Green data
26	G1	Green data Note2
27	G0	Green data (LSB) Note2
28	R7	Red Data(MSB) Note2
29	R6	Red Data
30	R5	Red Data
31	R4	Red Data

32	R3	Red Data	
33	R2	Red Data	
34	R1	Red Data	Note2
35	R0	Red Data(LSB)	Note2
36	GND	Power Ground	
37	DCLK	Pixel clock	Note3
38	GND	Power Ground	
39	L/R	Left/right selection	Note4/5
40	U/D	up/down selection	Note4/5
41	VGH	Gate ON Voltage	
42	VGL	Gate OFF Voltage	
43	AVDD	Power for Analog Circuit	
44	RESET	Global reset pin	Note6
45	NC	NO connection	
46	Vcom	Common Voltage	
47	DITHB	Dithering function	Note7
48	GND	Power Ground	
49	NC	NO connection	
50	NC	NO connection	

Note 1: DE/SYNC mode select. Normally pull high.

When select DE mode, MODE="1", VS and HS must pull high.

When select SYNC mode, MODE="0", DE must be grounded.

Note 2: When input 18 bits RGB data, the two low bits of R,G and B data must be grounded.

Note 3: Data shall be latched at the falling edge of DCLK.

Note 4: Selection of scanning mode

Setting of scan control input		Scanning direction
U/D	L/R	
GND	DV _{DD}	Up to down, left to right
DV _{DD}	GND	Down to up, right to left
GND	GND	Up to down, right to left
DV _{DD}	DV _{DD}	Down to up, left to right

Note 5: Definition of scanning direction.
Refer to the figure as below:

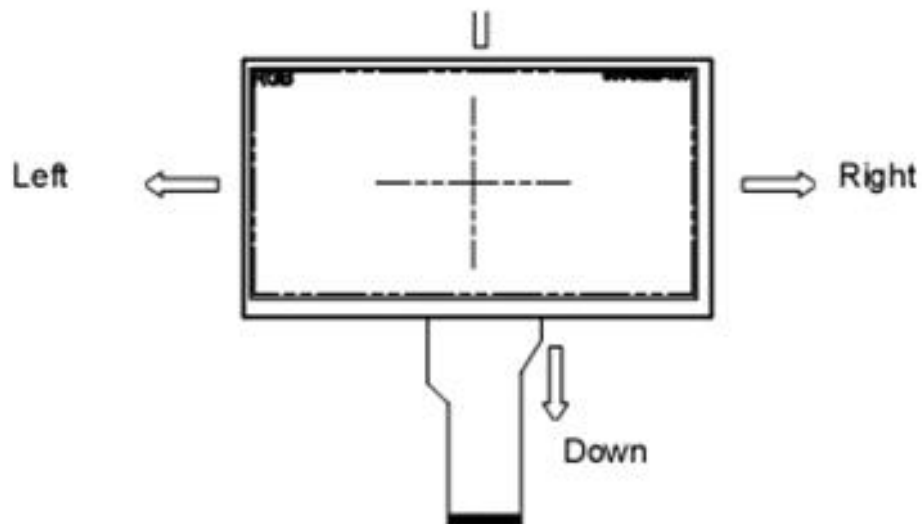

Note 6: Global reset pin. Active low to enter reset state. Suggest to connect with an RC reset circuit for stability. Normally pull high.

Note 7: Dithering function enable control, normally pull high.
When DITHB="1", Disable internal dithering function,
When DITHB="0", Enable internal dithering function,

Note 8: Reserve for LED power input.



4 Absolute Maximum Ratings

(Note 1)

Item	Symbol	Values		Unit	Remark
		Min.	Max.		
Power voltage	DV _{DD}	-0.3	5.0	V	
	AV _{DD}	6.5	13.5	V	
	V _{GH}	-0.3	40.0	V	
	V _{GL}	-20.0	0.3	V	
	V _{GH} -V _{GL}	-	40.0	V	
Operation Temperature	T _{OP}	-20	70	°C	
Storage Temperature	T _{ST}	-30	80	°C	

Note 1: The absolute maximum rating values of this product are not allowed to be exceeded at any times. Should a module be used with any of the absolute maximum ratings exceeded, the characteristics of the module may not be recovered, or in an extreme case, the module may be permanently destroyed.

5 Electrical Characteristics

5.1 Driving TFT LCD Panel

Item	Symbol	Values			Unit	Remark
		Min.	Typ.	Max.		
Power voltage	DV_{DD}	3.0	3.3	3.6	V	Note 2
	AV_{DD}	10.2	10.4	10.6	V	
	V_{GH}	15.3	16.0	16.7	V	
	V_{GL}	-7.7	-7.0	-6.3	V	
Input signal voltage	V_{COM}	3.6	3.8	4.0	V	
Input logic high voltage	V_{IH}	0.7 DV_{DD}	-	DV_{DD}	V	Note 3
Input logic low voltage	V_{IL}	0	-	0.3 DV_{DD}	V	

Note 1: Be sure to apply DV_{DD} and V_{GL} to the LCD first, and then apply V_{GH}

Note 2: DV_{DD} setting should match the signals output voltage (refer to Note 3) of customer's system board.

Note 3: DCLK, HS, VS, RESET, U/D, L/R, DE, R0~R7, G0~G7, B0~B7, MODE, DITHB.

Item	Symbol	Values			Unit	Remark
		Min.	Typ.	Max.		
Current for Driver	I_{GH}	-	0.2	1.0	mA	$V_{GH} = 16.0V$
	I_{GL}	-	0.2	1.0	mA	$V_{GL} = -7.0V$
	IDV_{DD}	-	4.0	10	mA	$DV_{DD} = 3.3V$
	$I_{AV_{DD}}$	-	20	50	mA	$AV_{DD} = 10.4V$



5.2.1 Interface Timing

Item	Symbol	Values			Unit	Remark
		Min.	Typ.	Max.		
HS setup time	T_{hst}	8	-	-	ns	
HS hold time	T_{hhd}	8	-	-	ns	
VS setup time	T_{vst}	8	-	-	ns	
VS hold time	T_{vhd}	8	-	-	ns	
Data setup time	T_{dsu}	8	-	-	ns	
Data hole time	T_{dhd}	8	-	-	ns	
DE setup time	T_{esu}	8	-	-	ns	
DE hole time	T_{ehd}	8	-	-	ns	
DV _{DD} Power On Slew rate	T_{POR}	-	-	20	ms	From 0 to 90% DV _{DD}
RESET pulse width	T_{Rst}	1	-	-	ms	
DCLK cycle time	T_{coh}	20	-	-	ns	
DCLK pulse duty	T_{cwh}	40	50	60	%	

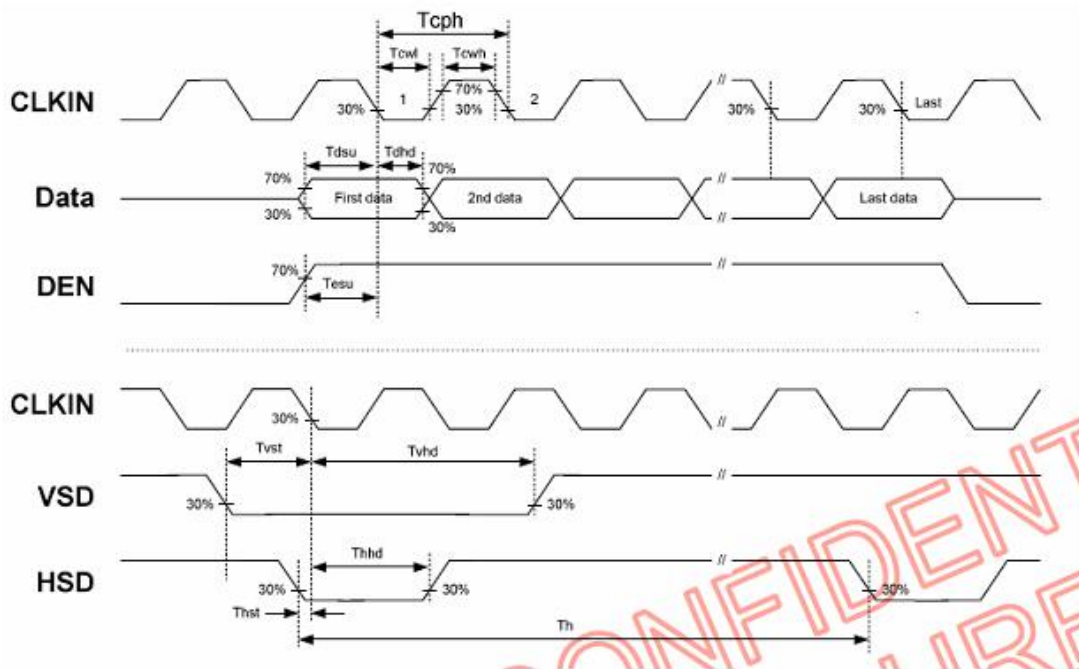

5.2.2 Recommended Timing Setting of TCON

TCON (Embedded In Source IC) Input Timing (DCLK, HSD, VSD, ED)

Item	Symbol	Values			Unit	Remark
		Min.	Typ.	Max.		
Horizontal Display Area	thd	-	800	-	DCLK	
DCLK Frequency	fclk	26.4	33.3	46.8	MHz	
One Horizontal Line	th	862	1056	1200	DCLK	
HS pulse width	thpw	1	-	40	DCLK	
HS Blanking	thb	46	46	46	DCLK	
HS Front Porch	thfp	16	210	354	DCLK	

Item	Symbol	Values			Unit	Remark
		Min.	Typ.	Max.		
Vertical Display Area	tvd	-	480	-	TH	
VS period time	tv	510	525	650	TH	
VS pulse width	tvpw	1	-	20	TH	
VS Blanking	tvb	23	23	23	TH	
VS Front Porch	tvfp	7	22	147	TH	

5.3 Driving Backlight

Item	Symbol	MIN	TYP	MAX	Unit	Remark
Forward Current	I_F	-	120	-	mA	
Forward Voltage	V_F	9.0	9.6	10.6	V	
Backlight Power consumption	W_{BL}	-	TBD	-	W	

Note 1: Each LED : $I_F = 60 \text{ mA}$, $V_F = 3.2\text{V}$.

Note 2: Optical performance should be evaluated at $T_a = 25^\circ\text{C}$ only.

Note 3: If LED is driven by high current, high ambient temperature & humidity condition. The life time of LED will be reduced. Operating life means brightness goes down to 50% initial brightness. Typical operating life time is estimated data.

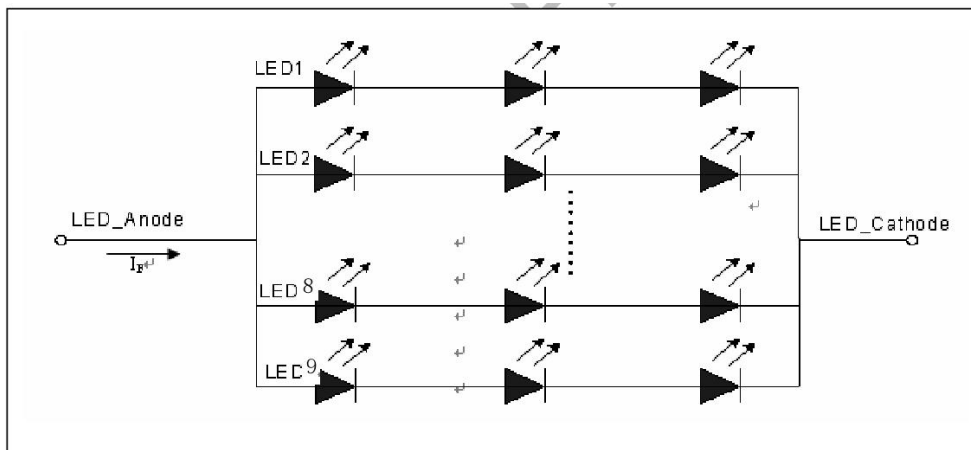

Figure : LED connection of backlight

6 Optical Characteristics

Items	Symbol	Condition	Min.	Typ.	Max.	Unit	Remark	
Viewing angles	θ_L		60	70	-	Degree.	Note2	
	θ_R		60	70	-			
	θ_T		40	50	-			
	θ_B		60	70	-			
Contrast Ratio	CR	$\Theta = 0$	400	500	-	-	Note1, Note3	
Response Time	T_{ON}	$25^\circ C$	-	10	20	ms	Note1, Note4	
	T_{OFF}		-	15	30			
Chromaticity	White	Normal $\Theta = 0^\circ$	X_W	0.26	0.31	0.36	-	Note1, Note5
			Y_W	0.28	0.33	0.38	-	
Color Gamut			NTSC	-	50	-	%	Note1, Note6
Luminance	L				200			Note1, Note7

Test Conditions:

1. $V_{DD}=3.3V$, the ambient temperature is $25^\circ C$.
2. The test systems refer to Note 1 and Note 2.

Note 1: Definition of optical measurement system.

The optical characteristics should be measured in dark room. After 5 minutes operation, the optical properties are measured at the center point of the LCD screen. All input terminals LCD panel must be ground when measuring the center area of the panel.

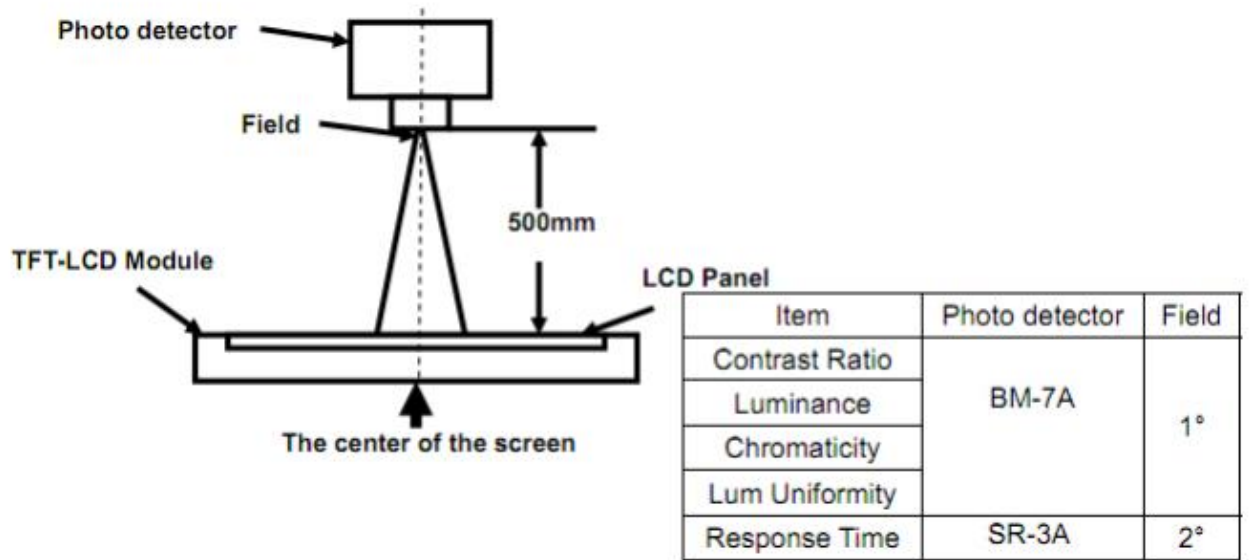

Note 2: Definition of viewing angle range and measurement system.
viewing angle is measured at the center point of the LCD by CONOSCOPE(ergo-80).

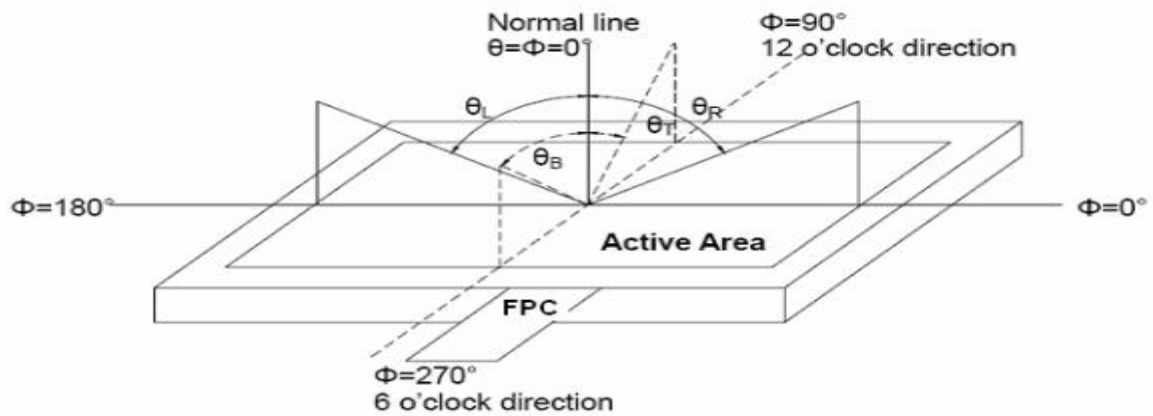

Fig. 1 Definition of viewing angle

Note 3: Definition of contrast ratio

$$\text{Contrast ratio (CR)} = \frac{\text{Luminance measured when LCD is on the "White" state}}{\text{Luminance measured when LCD is on the "Black" state}}$$

Note 4: Definition of Response time

The response time is defined as the LCD optical switching time interval between "White" state and "Black" state. Rise time (TON) is the time between photo detector output intensity changed from 90% to 10%. And fall time (TOFF) is the time between photo detector output intensity changed from

10% to 90%.

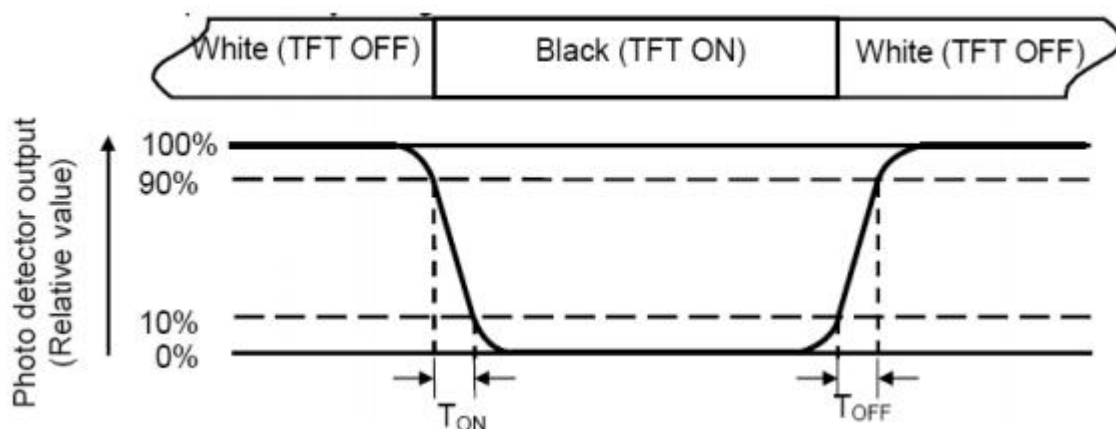

Note 5: Definition of color chromaticity (CIE1931)

Color coordinates measured at center point of LCD.

Note 6: Definition of Luminance Uniformity

Active area is divided into 9 measuring areas (Refer Fig. 2). Every measuring point is placed at the center of each measuring area.

Luminance Uniformity(U) = $L_{min} / L_{max} \times 100\%$

L-----Active area length W----- Active area width

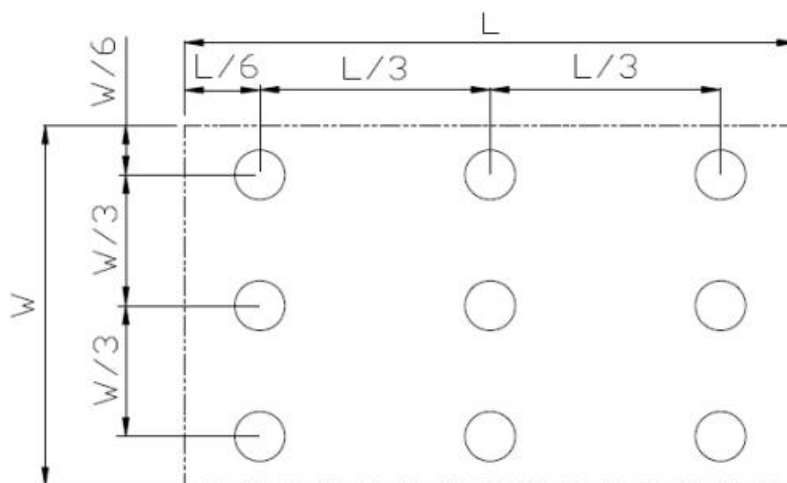

Fig. 2 Definition of uniformity

L_{max} : The measured maximum luminance of all measurement position.

L_{min} : The measured minimum luminance of all measurement position.

Note 7: Definition of Luminance :

Measure the luminance of white state at center point.

7 Environmental / Reliability Tests

No	Test Item	Condition	Remarks
1	High Temperature Opeartion	T _s = +70℃, 240hrs	Note 1 IEC60068-2-2, GB2423. 2-89
2	Low Temperature Opeartion	T _a = -20℃, 240hrs	Note 2 IEC60068-2-1 GB2423.1-89
3	High Temperature Storage	T _a = +80℃, 240hrs	IEC60068-2-2 GB2423. 2-89
4	Low Temperature Storage	T _a = -30℃, 240hrs	IEC60068-2-1 GB/T2423.1-89
5	High Temperature & Humidity Storage	T _a = +60℃, 90% RH max, 160 hours	IEC60068-2-3 GB/T2423.3-2006
6	Thermal Shock (Non-operation)	-30℃ 30 min ~ +80℃ 30 min Change time: 5min, 30 Cycle	Start with cold temperature, end with high temperature IEC60068-2-14, GB2423.22-87
7	Electro Static Discharge (Opeartion)	C=150pF, R=330 Ω, 5 points/panel Air: ±8KV, 5 times; Contact: ±4KV, 5 times; (Environment: 15℃ ~ 35℃, 30% ~ 60%, 86Kpa ~ 106Kpa)	IEC61000-4-2 GB/T17626.2-1998
8	Vibration (Non-operation)	Frequency range: 10~55Hz, Stroke: 1.mm Sweep: 10Hz~55Hz~10Hz 2 hours for each direction of X .Y. Z. (package condition)	IEC60068-2-6 GB/T2423.5-1995
9	Shock (Non-operation)	60G 6ms, ± X, ± Y, ± Z 3 times for each direction	IEC60068-2-27 GB/T2423.5-1995
10	Package Drop Test	Height: 80 cm, 1 corner, 3 edges, 6 surfaces	IEC60068-2-32 GB/T2423.8-1995

Note: 1. T_s is the temperature of panel's surface.
2. T_a is the ambient temperature of sample.



3. Mechanical drawing

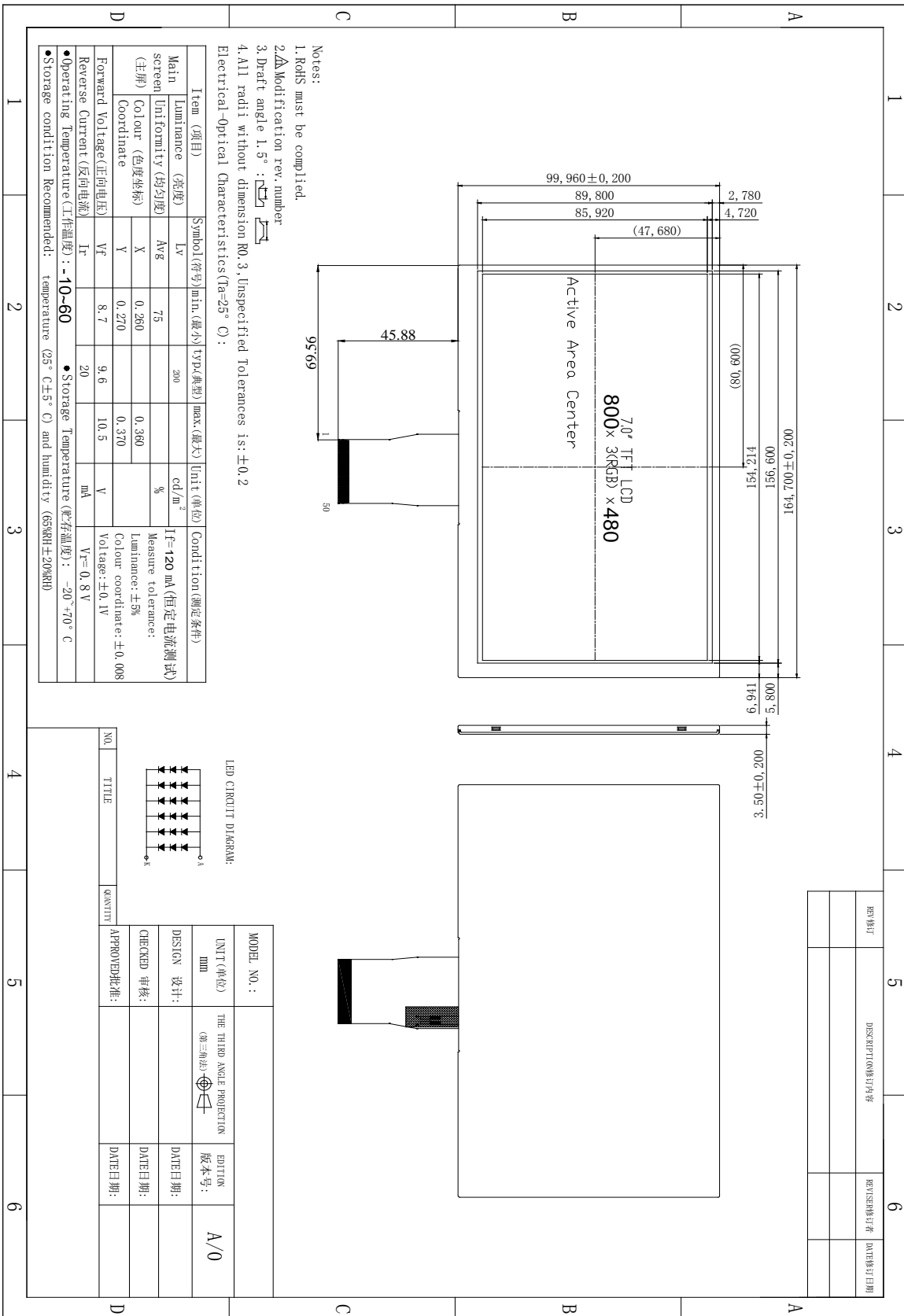



深圳市泰奕达科技有限公司
Shenzhen Taiyidai Technology Co., Ltd.

9 Packing

TBD

10. Precautions for Use of LCD modules

10.1 Handling Precautions

10.1.1. The display panel is made of glass. Do not subject it to a mechanical shock by dropping it from a high place, etc.

10.1.2. If the display panel is damaged and the liquid crystal substance inside it leaks out, be sure not to get any in your mouth, if the substance comes into contact with your skin or clothes, promptly wash it off using soap and water.

10.1.3. Do not apply excessive force to the display surface or the adjoining areas since this may cause the color tone to vary.

10.1.4. The polarizer covering the display surface of the LCD module is soft and easily scratched. Handle this polarizer carefully.

10.1.5. If the display surface is contaminated, breathe on the surface and gently wipe it with a soft dry cloth. If still not completely clear, moisten cloth with one of the following solvents:

- Isopropyl alcohol
- Ethyl alcohol

Solvents other than those mentioned above may damage the polarizer. Especially, do not use the following:

- Water — Ketone
- Aromatic solvents

10.1.6. Do not attempt to disassemble the LCD Module.

10.1.7. If the logic circuit power is off, do not apply the input signals.

10.1.8. To prevent destruction of the elements by static electricity, be careful to maintain an optimum work environment.

10.1.8.1. Be sure to ground the body when handling the LCD Modules.

10.1.8.2. Tools required for assembly, such as soldering irons, must be properly ground.

10.1.8.3. To reduce the amount of static electricity generated, do not conduct assembly and other work under dry conditions.

10.1.8.4. The LCD Module is coated with a film to protect the display surface. Be care when peeling off this protective film since static electricity may be generated.

10.2 Storage Precautions

10.2.1. When storing the LCD modules, avoid exposure to direct sunlight or to the light of fluorescent lamps.

10.2.2. The LCD modules should be stored under the storage temperature range. If the LCD modules will be stored for a long time, the recommend condition is:

Temperature : 0°C ~ 40°C Relatively humidity: ≤80%

10.2.3. The LCD modules should be stored in the room without acid, alkali and harmful gas.

10.3 Transportation Precautions

The LCD modules should be no falling and violent shocking during transportation, and also should avoid excessive press, water, damp and sunshine.